



2020 Entry

11+ Entrance Examination  
Guidelines and Sample Questions

English (1 hour)

Maths (1 hour)

Verbal Reasoning (15 mins)



## Information for Parents

Entrance exams can be stressful for families and we want to make the admissions process as straightforward as possible. These sample papers are to give you and your child an idea of what the exam will involve as well as identify any areas which your child may need to strengthen. Your child's current school should be able to recommend suitable practice resources if you feel that your child needs them.

We're often asked by parents how they can support their child in the run up to the Entrance Exam. Whilst each child is different, here are some things you can do at home. You can do as much or as little as you feel appropriate:

- Encourage your child to read! Reading all sorts of books and articles will give them lots of ideas about structuring writing and improve their vocabulary. Reading helps enormously with the Verbal Reasoning paper too.

If your child is reading a book, ask them about it. What do they like about it? Would they read another book by this author? Which friends would they lend it to and why? Libraries and bookshops are always happy to recommend books that might spark a reluctant reader's imagination.

Our English paper includes a creative writing element. Talk to your child about structure - planning a piece of writing with a beginning, middle and end. They will have 20 minutes for this task so it's useful if they know how long that is and how much they can get done in that time. We're looking for descriptive writing which is well-structured and flows but which is also correctly spelled and clearly written.

- Little and often is a good way to keep up your child's maths skills. Encourage them to use maths in the real world - working out percentages, adding up shopping and calculating distances can all be done out and about. There are lots of great online maths resources too that your child's teacher will be able to recommend.
- Puzzles and word games are a great way of helping your child prepare for the Verbal Reasoning paper. Anything from Scrabble to word searches will help your child's problem-solving skills as well as their vocabulary.
- Remind your child to work quickly and neatly. If they do not know the answer, they should move onto the next question and return to it at the end. It can be stressful to get 'stuck' on one question and lose valuable time trying to find the answer. They should also get into the habit of checking their work to make sure that they haven't lost marks on simple errors.
- We want to make Examination Day as relaxed as possible. The children are in small groups and work in classrooms, rather than one large hall. They are looked after by the same teacher all day and accompanied by a prefect. We do ask the children to wear school uniform as we find that this creates a working atmosphere but we give the children plenty of time to let off steam between exams and meet some children who may eventually become their classmates.

## Information for Children

- Don't panic! It's natural to feel nervous but we want you to do your best on the day.
- There will be three exams during the day with a break in between. At the start of each exam, the teacher will explain clearly what you need to do and how long you have. They will also give you an idea of what time you have left, so that you can plan your work accordingly.
- If you're the only person from your school, please don't worry. Every year we get lots of children sitting the exam who don't know anyone else. We look after everyone during the day to make sure that everybody has someone to talk to.
- There are lots of things you can do to prepare for the exam - we've given some tips on the previous page for things that your parents can help you with. It's helpful to read lots, try to use your maths in everyday situations (shops, trips, etc), play games and solve puzzles. Visits to museums, art galleries and other events should give you inspiration too.
- Look after yourself in the run up to the exam - exercise, eat healthily and get lots of sleep. We want you to do your best and we will do everything we can to make the day as stress-free as possible for you.

# 11+ Examination Guidelines

## 11+ English Examination (1 hour)

The examination will last 1 hour and there are two sections:

### **Section A: Reading (40 minutes)**

Candidates will be given a short reading passage (fiction) and asked a series of questions based on this. At first, questions will test explicit understanding of the passage - asking for fact retrieval - as well as requiring identification of literary and grammatical features. Then a series of quotations will be provided, asking candidates to engage with and respond to the language and literary techniques used. The final section comprises a longer written response to a short extract from the passage.

### **Section B: Writing (20 minutes)**

In Section B, pupils will demonstrate the accuracy and imagination of their writing by completing a short descriptive task. We are looking for engaging and lively ideas, varied and controlled grammatical features, and a broad, ambitious vocabulary that is spelled correctly. Pupils should use paragraphing and appropriate punctuation to make the sequence of events or ideas coherent and clear to the reader. We acknowledge that the response will be relatively short with just 20 minutes for the task.

## Sample Passage

### The Lost World

By Arthur Conan Doyle

***Journalist Ed Malone is on an expedition in the South American jungle in the 19<sup>th</sup> century when his party stumble across an undiscovered region where dinosaurs still survive. In this extract, he has crept out of their camp at night to explore and is on the way back when something terrible happens.***

I was plodding up the slope, turning these thoughts over in my mind, and had reached a point which may have been half-way to home, when my mind was brought back to my own position by a strange noise behind me. It was something between a snore and a growl, low, deep, and exceedingly menacing. Some strange creature  
5 was evidently near me, but nothing could be seen, so I hastened<sup>1</sup> more rapidly on my way. I had traversed<sup>2</sup> half a mile or so when suddenly the sound was repeated, still behind me, but louder and more menacing than before. My heart stood still within me as it flashed across me that the beast, whatever it was, must surely be after *me*. My skin grew cold and my hair rose at the thought...

10 I stood like a man paralysed, still staring at the ground which I had traversed. Then suddenly I saw it. There was a movement among the bushes at the far end of the clearing which I had just traversed. A great dark shadow disengaged<sup>3</sup> itself and hopped out into the clear moonlight... It was of enormous size and power, like an erect elephant, but its movements, in spite of its bulk, were exceedingly alert. For a  
15 moment, as I saw its shape, I hoped that it was an iguanodon, which I knew to be harmless, but, ignorant as I was, I soon saw that this was a very different creature. Instead of the gentle, deer-shaped head of the great three-toed leaf-eater, this beast had a broad, squat, toad-like face like that which had alarmed us in our camp. His ferocious cry and the horrible energy of his pursuit both assured me that this was  
20 surely one of the great flesh-eating dinosaurs, the most terrible beasts which have ever walked this earth. As the huge brute loped along it dropped forward upon its

---

<sup>1</sup> *hastened* – moved quickly

<sup>2</sup> *traversed* – travelled across or through

<sup>3</sup> *disengaged* – separated from something

forepaws<sup>4</sup> and brought its nose to the ground every twenty yards or so. It was smelling out my trail...

25 Even now when I think of that nightmare the sweat breaks out upon my brow. What could I do? ... My only possible chance lay in flight. I could not move swiftly over the rough, broken ground, but as I looked around me in despair I saw a well-marked, hard-beaten path which ran across in front of me. We had seen several of the sort, the runs of various wild beasts during our expeditions. Along this I could perhaps hold my own, for I was a fast runner, and in excellent condition. Flinging away my  
30 useless gun, I set myself to do such a half mile as I have never done before or since. My limbs ached, my chest heaved, I felt that my throat would burst for want of air, and yet with that horror behind me I ran and ran and ran. At last I paused, hardly able to move. For a moment I thought that I had thrown him off. The path lay still behind me. And then suddenly, with a crashing and a rendering<sup>5</sup>, a thudding of giant  
35 feet and a panting of monster lungs, the beast was upon me once more. He was at my very heels. I was lost...

Up to then he had hunted by scent, and his movement was slow. But he had actually seen me as I started to run. From then onwards he had hunted by sight, for the path showed him where I had gone. Now, as he came round the curve, he was springing  
40 in great bounds. The moonlight shone upon his huge projecting eyes, the row of enormous teeth in his open mouth, and the gleaming fringe of claws upon his short, powerful forearms. With a scream of terror I turned and rushed wildly down the path. Behind me the thick, gasping breathing of the creature sounded louder and louder. His heavy footfall was beside me. Every instant I expected to feel his grip upon my  
45 back. And then suddenly there came a crash – I was falling through space, and everything beyond was darkness and rest.

---

<sup>4</sup> *forepaws* – paws on front feet or arms

<sup>5</sup> *rendering* – tearing apart of something

## Section A - Reading

You have 40 minutes in total to read the passage and complete Section A. Look carefully at the number of marks each question is worth to guide the length of your answer: a 6-mark question requires at least one paragraph of analysis.

### SECTION A (30 marks)

**Q1.** For each question below, circle the **one** correct answer. If you make a mistake or change your mind then simply cross this answer out and circle your final choice.

a. What is Ed doing when he first hears the sound of the dinosaur? [1 mark]

- A) Cooking his dinner
- B) Lighting a fire
- C) Walking back to his camp
- D) Tying his shoelaces

b. Look at line 4. What does 'menacing' mean here? [1 mark]

- A) Very quiet
- B) High-pitched
- C) Frightening
- D) Friendly

c. Look at line 11. What type of word is 'movement'? [1 mark]

- A) Verb
- B) Noun
- C) Adverb
- D) Adjective

d. In line 10, what technique is used in the phrase 'stood like a man paralysed'? [1 mark]

- A) Simile
- B) Metaphor
- C) Alliteration
- D) Onomatopoeia

e. Look at line 19. What type of word is 'horrible'? [1 mark]

- A) Adverb
- B) Verb
- C) Adjective
- D) Noun

f. What do you think happens at the very end of the extract? [1 mark]

- A) He makes it back to camp
- B) The dinosaur attacks him
- C) He falls off a cliff or into a hole
- D) He wakes up and realises it was all a bad dream



**Q2.** Read again the first part of the extract, from **lines 1 to 9**.

List **four things** we learn about the noise made by the dinosaur from this paragraph. **[4 marks]**

- 1. \_\_\_\_\_  
\_\_\_\_\_
- 2. \_\_\_\_\_  
\_\_\_\_\_
- 3. \_\_\_\_\_  
\_\_\_\_\_
- 4. \_\_\_\_\_  
\_\_\_\_\_

**Q3.** Look in detail at examples a, b, c and d (below) from the extract.

How does the writer use language and literary techniques in each example to make this scene exciting and fearful for the reader? Remember to name techniques where you spot them.

a. **Lines 6-9:** ‘suddenly the sound was repeated, still behind me, but louder and more menacing than before. My heart stood still within me as it flashed across me that the beast, whatever it was, must surely be after *me*. My skin grew cold and my hair rose at the thought...’

\_\_\_\_\_  
\_\_\_\_\_  
\_\_\_\_\_  
\_\_\_\_\_  
\_\_\_\_\_  
\_\_\_\_\_

**[2 marks]**

b. **Lines 12-4:** ‘A great dark shadow disengaged itself and hopped out into the clear moonlight... It was of enormous size and power, like an erect elephant, but its movements, in spite of its bulk, were exceedingly alert’

\_\_\_\_\_  
\_\_\_\_\_  
\_\_\_\_\_  
\_\_\_\_\_  
\_\_\_\_\_

**[2 marks]**

c. **Lines 17-20:** 'this beast had a broad, squat, toad-like face like that which had alarmed us in our camp. His ferocious cry and the horrible energy of his pursuit both assured me that this was surely one of the great flesh-eating dinosaurs'

---



---



---



---



---



---

[2 marks]

d. **Lines 39-42:** 'he was springing in great bounds. The moonlight shone upon his huge projecting eyes, the row of enormous teeth in his open mouth, and the gleaming fringe of claws upon his short, powerful forearms.'

---



---



---



---



---



---

[2 marks]

**Q4.** Complete the grid below to show the correct sequence for how the extract of the story is structured.

Put (1) in the box for the first section, then (2) for the next section and so on, to show the correct sequence. [6 marks]

Ed decides his only chance is to run from the beast, which he does, as fast as he can.	
He hears the noise again and realises that a creature is hunting him.	
The dinosaur reappears and chases Ed until he falls into a hole.	
Ed pauses, thinking he might have shaken the dinosaur off his trail.	
He sees the large dinosaur appear from the bushes and hopes it is harmless.	
Walking back to camp, Ed hears a strange growling behind him.	

**Q5.** Look below at the short extract from the passage. **Using quotations from this section alone**, analyse how the writer makes it tense and engaging for the reader. You may wish to consider:

- exciting vocabulary choices
- sentence structure
- use of literary techniques
- anything else you notice

*Flinging away my useless gun, I set myself to do such a half mile as I have never done before or since. My limbs ached, my chest heaved, I felt that my throat would burst for want of air, and yet with that horror behind me I ran and ran and ran. At last I paused, hardly able to move. For a moment I thought that I had thrown him off. The path lay still behind me. And then suddenly, with a crashing and a rendering<sup>6</sup>, a thudding of giant feet and a panting of monster lungs, the beast was upon me once more. He was at my very heels. I was lost...*

**[6 marks]**

---

---

---

---

---

---

---

---

---

---

---

---

---

---

---

---

---

---

---

---

---

---

---

---

---

---

<sup>6</sup> rendering – tearing apart of something



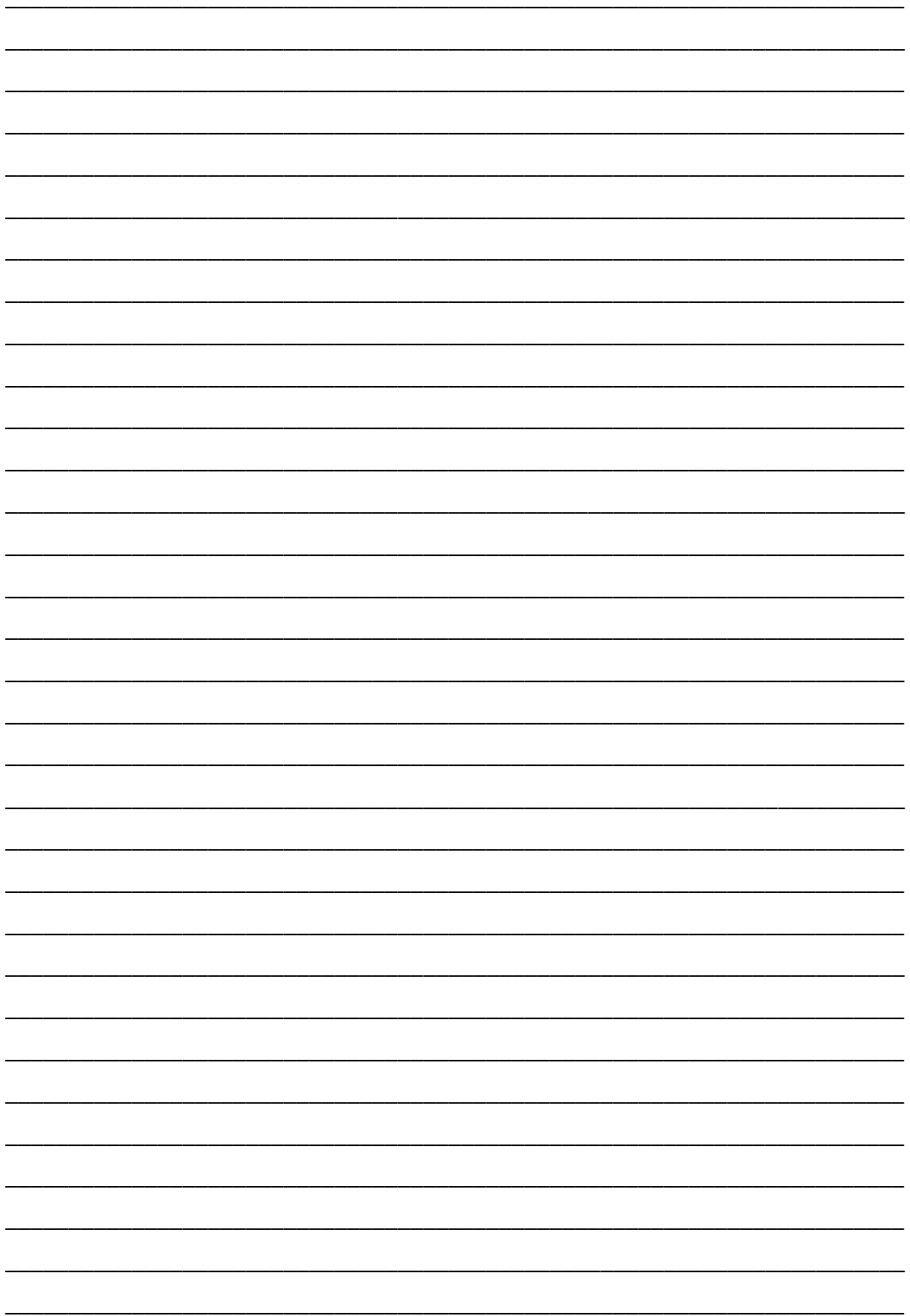

# 11+ Mathematics Examination (1 hour)

You have 1 hour in total to complete Sections A & B

There are two sections to the examination:

## Section A (30 marks) - 20 minutes

There will be a number of short questions testing a command of basic ideas from the syllabus; there may be some in-context questions but these will be straightforward.

## Section B (50 marks) - 40 minutes

The questions in Section B require longer responses. These questions will test the candidate's ability to apply mathematical reasoning in problem-solving contexts.

## Syllabus

Questions will be set on the Key Stage 2 programme of study.

For your information, the content that may be tested is:

- Multiply and divide whole numbers and decimals by 10, 100 and 1000
- Negative numbers (ordering, adding and subtracting)
- The four rules (+ – × ÷) applied to decimals to 2 places
- Simplifying fractions (“cancelling”)
- Fractional and percentage parts of quantities
- Addition and subtraction of fractions (including fractions with different denominators)
- Multiplying 3-digit numbers by 2-digit numbers
- Simple formulae and equations expressed in symbolic form
- Use of brackets
  
- Coordinates in all four quadrants
- Angles measured as part rotations and in degrees
- Angles of a triangle add to  $180^\circ$ ; angles at a point add to  $360^\circ$
- Symmetry (line and rotational) of 2D shapes
- Conversion of metric units to other metric units
- Approximate metric equivalents of imperial units still in daily use (these will be given)
- Estimates relating to everyday objects (height, weight, volume etc.)
- Area of a rectangle and triangle
  
- Calculating mean, median, mode and range for a list of data
- Pie charts
- Probability line
- Simple probability calculations (equally likely outcomes)
- Experimental probability

## Sample Paper (Mathematics)

You must use the answer boxes where they are provided.

Do your working in the space surrounding the questions.

In Section A only your answer gains the marks.

In Section B there are marks for your working as well as for the answer so **show working clearly**.

Equipment **allowed**: pens, pencils, ruler.

Equipment **prohibited**: protractor, calculator.

### Section A (30 marks) - 20 minutes

1. Calculate  $123 + 468$

[1]

2. Calculate  $648 \times 5$

[1]

3. Calculate  $3192 \div 7$

[1]

4. Calculate  $513 - 236$

[1]

5. Find  $\frac{2}{5}$  of £45

£

[1]

6. Put these into increasing order  $0.3$ ,  $\frac{4}{20}$ ,  $25\%$ ,  $\frac{9}{99}$

A B C D

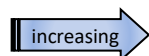

write four letters in the box ....

[1]

7. Calculate  $7 \times 0.4$

[1]

8. Calculate  $\frac{5}{12} - \frac{1}{4}$

[1]

9. If I leave home at 08:24 and arrive at work at 10:17, what was my journey time?

hr

min

[1]

10. Find 35% of \$80  \$ [1]
11. What is the next term in this sequence:  
7, 15, 23, 31, ... ?  [1]
12. Write down the number which is halfway between 17  
and 35  [1]
13. Calculate  $7 + 8 \times 3$   [1]
14. Calculate  $67 \times 23$   [1]
15. Calculate  $(124 + 231) \div 5$   [1]
16. Calculate 25% of 64 kg  kg [1]
17. 18 has six factors; two of them are 1 and 3;  
write down the other four  [1]
18. What is the **7th term** in this sequence: 11, 8, 5, 2, ... ?  [1]
19. 1 kg is approximately 2.2 lbs (pounds). Roughly how  
many pounds is 5 kg?  lbs [1]
20. Write the number 7 400 040 in words  
 [1]
21. If 30% of £P is £21, what is P?  P = [1]
22. What is the smallest odd number that can be written  
using all the digits 4, 6, 2, 5 once only?  [1]



23. If I buy 7 pencil sharpeners costing 14p each and pay with £1, what change do I receive?  p [1]
24. How many minutes are there in  $2\frac{1}{2}$  hours?  mins [1]
25. 9 and 16 are called square numbers because  $9 = 3 \times 3$  and  $16 = 4 \times 4$ .  
Which numbers in this list are square numbers: 1, 10, 100, 1000, 10000?  [1]
26. I think of a number, multiply it by 9 then add 5 and end up with 113. What number did I think of?  [1]
27. A bag contains 20 discs; 9 of them are red, 7 of them are green and the rest are blue.  
A disc is drawn at random; what is the probability that it is blue?  
Give your answer as a fraction in its simplest form.  [1]
28. Calculate  $5 \times 57 \times 4$   [1]
29. 6 bottles of spring water cost £2.52.  
How much do 9 bottles cost?  £ [1]
30. Calculate  $30 + 30 \times 30 + 30 \times 30 \times 30$   [1]

~ End of Section A ~

Section B (50 marks) - 40 minutes

1. Leonardo da Vinci, a famous Italian Mathematician, wrote some of his manuscripts in 'mirror writing' to add mystery. For example he would write the word TRAM like this: MART How would he have written the word PEST? [2]

1

2. Each box represents a missing digit (number). Fill in the missing digits: [8]

(a)  $\square \times 9 = \square 4$

(b)  $1\square \times 8 = \square\square 2$

(c) 
$$\begin{array}{r} 5\square \\ + \square 8 \\ \hline 97 \end{array}$$

(d) 
$$\begin{array}{r} 420 \\ - 2\square 4 \\ \hline \square 46 \end{array}$$

3. This table shows information about four solid shapes. Complete the table. One has been done for you. [3]

	Number of <b>flat</b> surfaces	Number of <b>curved</b> surfaces
Sphere	0	1
Cone		
Square based pyramid		
Cylinder		

4. James, Ben, Sarah and Amy take turns to have a shower in the morning. James (the oldest) **always goes first**. Using their initials (A = Amy etc.), list all the possible orders in which they could take their showers. One has been done for you [2]

4 JBSA

5. David and Katherine have some biscuits. Altogether they have 39 biscuits. David has 3 more biscuits than Katherine does. How many biscuits do David and Katherine each have? [2]

5 David: Katherine:

6. Here is a simplified map showing the shortest distances by road between three towns, Ascom, Felton and Monkton.

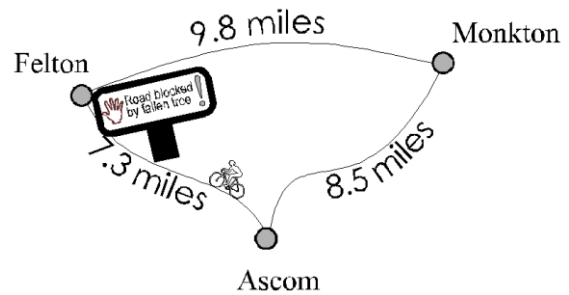

- (a) Ben is going to cycle from Felton to Ascom, but the direct route is blocked (storm damage!). So, instead he goes via Monkton. [1]

How far does Ben cycle ?

**6a** miles

- (b) How much **further** will Ben have to cycle as a result of not being able to take the direct route? [2]

**6b** miles

7. Alex makes a fruit salad using bananas, oranges and apples. For every 1 apple, she uses 2 bananas and 3 oranges. Alex uses 24 fruits; how many **bananas** does she use? [2]

**7** bananas

Kirsty's Greengrocers		
<i>Potatoes</i> 2kg bags, £1.50 each	<i>Carrots</i> 68p per kg	<i>Turnips</i> 72p per kg
**** <i>Special Offer - 5 bags of potatoes for £6</i> ****		
Opening times: Mon - Sat inclusive 8:30am - 5:00pm		

8. (a) Find the (cheapest) total cost of: five bags of potatoes and  $3\frac{1}{2}$  kg of turnips. [2]

**8a** £

- (b) For how many hours each week is Kirsty's shop open? [2]

**8b** hours

9. Here is an equilateral triangle inside a square. The perimeter of the triangle is 51 centimetres. What is the perimeter of the shaded area? [2]

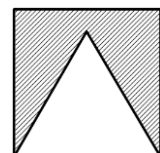

**9** cm

10. (a) Two angles are  $27^\circ$  and  $36^\circ$ . Find the third angle.

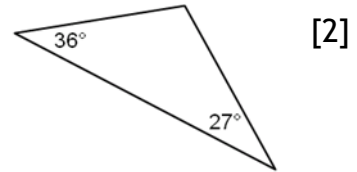

**10a**  ° [2]

- (b) The angles marked  $y$  are equal. Calculate  $y$ .

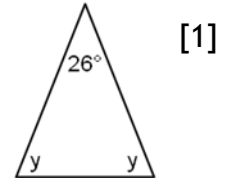

**10b**  $y =$   ° [1]

11.

		8
	5	1

Complete the magic square so that the numbers in every row, every column and both diagonals add up to 15. [2]

12. (a) Draw three more lines to correctly show the mean, median and range of these seven numbers: 1, 2, 5, 1, 5, 6, 1

Mean            5 [2]  
 Mode            2  
 Median          3  
 Range           1

- (b) Three single digit whole numbers have a mean of 7. One of them is 4; what are the other two numbers? [2]

**12b**  and

13. The  $*$  operator works like this:  $p * q = \frac{p}{1+q}$ , for example  $3 * 8 = \frac{3}{1+8} = \frac{1}{3}$

- (a) Find the value of:  $6 * 10$  [1]

**13a**

- (b) Find the value of:  $4 * 7$  (giving your answer in its simplest form) [1]

**13b**

- (c) If  $2 * q = 0.2$ , what is  $q$ ? [1]

**13c**  $q =$

14. A maths teacher hangs a picture of a triangle on his wall. The outer dimensions of the frame are 60cm by 34cm and the frame is 2cm wide. The picture shows a triangle and measurements are given. The triangle is drawn on canvas.

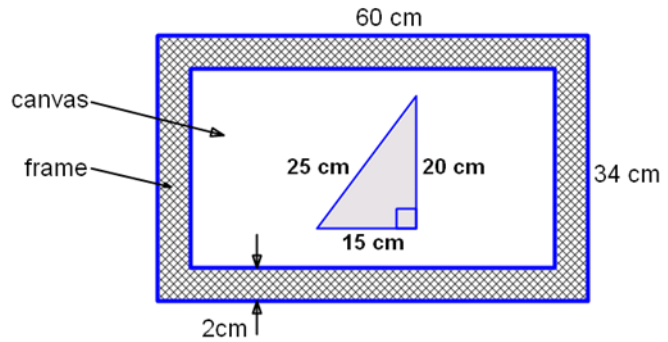

- (a) Calculate the area of the triangle [2]

**14a**  cm<sup>2</sup>

- (b) Calculate the area of canvas **visible** (part of it is covered by the triangle) [3]

**14b**  cm<sup>2</sup>

15. In the number system on Planet Zog, only one-digit numbers occur, using any of the digits 0 to 9. Counting proceeds in the normal way until 9 is reached, then the next number is 0 and the whole sequence repeats itself. Addition and multiplication can be performed as normal except that only the units digit of the answer is taken.

So, for example,  $7 + 8 = 5$ , since usually  $7 + 8 = 15$ , and  $7 \times 8 = 6$ , since usually  $7 \times 8 = 56$

- (a) Find  $8 + 8$  [1]

**15a**

- (b) Find  $7 \times 7$  [1]

**15b**

$P$ ,  $Q$  and  $R$  are all single digit numbers

[1]

- (c) If  $8 + P = 4$ , find the value of  $P$

**15c**  $P =$

- (d) If  $7 \times Q = 8$ , find the value of  $Q$  [1]

**15d**  $Q =$

- (e) If  $6 \times R = 4$ , find two values of  $R$  [1]

**15e**  $R =$   or

## Verbal Reasoning Practice Paper

On Examination Day, candidates will be given the opportunity to undertake a short practice session before they attempt the actual paper. This practice takes 15 minutes and the supervising member of staff will go through the answers with the candidates. Candidates mark their own practice paper and can ask for guidance if they are unclear on what the paper involves.

They are then given 45 minutes to complete the Verbal Reasoning paper. This paper requires children to work quickly and accurately. We recommend that candidates skip any questions they cannot answer and return to them at the end. Any remaining time should be used to double check their answers.

You have 15 minutes in total to complete the Verbal Reasoning Practice Paper.

1. Underline the word in brackets that means the opposite of 'careful'.

(brave/caring/boring/careless/neat)

The six words below can be made into two groups of three:

*measures of time*  
week / year / two / day / three / one  
*numbers*

If we re-arrange the words in each group 'week' will be in the middle of one group and 'two' the middle of the other group:

week / year / two / day / three / one

2. In the question below, underline the middle word in each group.

smaller / hut / small / castle / house / smallest

The words in the groups A to C below are alike in some way but different from the words in the other groups.

A	B	C
wren	hour	red
robin	minute	yellow
thrush	second	blue

3. Now write a letter beside this word to show which group it belongs to.

year (.....)

GO ON TO THE NEXT PAGE

Here are three words:  
HOT TON NOT

Below you will find the same three words written in a secret code, and in a different order. All the words are written in the same code.

**Work out which word each code stands for, and write the word in the brackets beside its code word. Spell correctly.**

4. ω γ ψ (.....)

5. ζ γ ψ (.....)

6. ψ γ ω (.....)

7. This question makes use of a code.  
**Underline** the correct word in the brackets.  
If LGRT stands for 'date', TGR stands for (tea / east / eat / ate / art).

The alphabet is printed below to help you with the next question.  
A B C D E F G H I J K L M N O P Q R S T U V W X Y Z

8. The row of letters below follows a rule. Add the next two letters in the row.  
A, C, E, ....., .....

Look at this example:  
dot, lot; dip, lip; date, (late)

We have to find the rule by which the second word of each pair is made up from the first. By changing 'd' into 'l', 'dot' becomes 'lot' and 'dip' becomes 'lip'. In the same way, from 'date' we get 'late' so we have written 'late' into the brackets.

9. Now do this.  
sent, nest; node, done; dame, (.....)

Look at this example:  
dog / horse / field / lion / mouse / tail

Four of these words are the names of animals and may be grouped together.

We have underlined the other two words - 'field' and 'tail'.

10. Now do this one. **Underline** the *two* words that *do not* belong with the other four.  
yellow / colour / blue / red / paint / green

	<p>Look at this example - the letters of one word have been jumbled up: PHOS is a place where you buy things. (SHOP)</p> <p>The letters PHOS are just the letters of 'shop' in another order; so we have written 'SHOP' in the brackets.</p>
<b>11.</b>	<p><b>Now do the next one in the same way. Write the proper word in the brackets.</b></p> <p>LUBE is a colour (.....)</p>

**END OF PRACTICE PAPER**



# Sample Paper Answers

## English: Section A - Reading

Q1. For each question below, circle the **one** correct answer. If you make a mistake or change your mind then simply cross this answer out and circle your final choice.

- |    |   |    |   |
|----|---|----|---|
| a. | C | d. | A |
| b. | C | e. | C |
| c. | B | f. | C |

[6 marks]

Q2. Read again the first part of the extract, from **lines 1 to 9**.

List **four things** we learn about the noise made by the dinosaur from this paragraph.

[4 marks]

One mark for each of the following, either paraphrased or quoted:

- **strange**
- **like a snore or a growl**
- **low (as in volume)**
- **deep (as in pitch)**
- **menacing/frightening**
- **louder (upon repetition)**

**DO NOT credit 'behind him'**

Q3. Look in detail at examples a, b, c and d from the extract.

How does the writer use language and literary techniques in each example to make this scene exciting and fearful for the reader? Remember to name techniques where you spot them.

**ONE MARK** for EITHER explaining the effect of a piece of language or technique OR for correctly naming one of the techniques.

**TWO MARKS** for analysing AND naming a technique

**TWO MARKS** for analysing TWO examples of language/techniques without naming them

Some suggested analysis below but credit anything you think is worthy and/or correct:

a. **Lines 6-9:** ‘suddenly the sound was repeated, still behind me, but louder and more menacing than before. My heart stood still within me as it flashed across me that the beast, whatever it was, must surely be after *me*. My skin grew cold and my hair rose at the thought...’

- Adverb ‘suddenly’ introduces an abrupt change of tone and pace, creating tension.
- ‘Louder’ and ‘more menacing’ imply the creature is approaching him from behind, making him seem vulnerable, as if he is being hunted. ‘Menacing’ has sinister overtones.
- The hyperbole of ‘my heart stood still’ suggests Ed’s fear, as if even his heart goes quiet for fear of giving his position away to the dinosaur. Possibly foreshadows his death?
- ‘Flashed’ across me is metaphorical, perhaps even an onomatopoeia. Implies a sudden realisation, suggesting force and impact.
- ‘Whatever it was’ leaves it to our imagination, allowing us to picture the worst.
- ‘Skin grew cold’ etc. is further example of typical reaction of fear. An extreme physical response, showing the extent of Ed’s terror.

[2 marks]

b. **Lines 12-4:** ‘A great dark shadow disengaged itself and hopped out into the clear moonlight... It was of enormous size and power, like an erect elephant, but its movements, in spite of its bulk, were exceedingly alert’

- Adjectives ‘great’ and ‘dark’, and the noun ‘shadow’ indicate size but also mystery as it’s not yet revealed. Fear of the unknown.
- ‘Hopped’ is an unusual verb choice; suggests power and agility in spite of its size. Also animalistic. Be generous in crediting their attempts with this word!
- Descriptive detail of ‘moonlight’ sets a spooky/gothic scene, also reveals the beast in its full glory.
- ‘Enormous size and power’, as well as ‘bulk’ suggests the sheer scale and weight of the dinosaur, making Ed seem tiny and insignificant.
- Simile: ‘like an erect elephant’ is again animalistic, also emphasising its size as elephants are the bulkiest land animals in our world today.
- ‘Exceedingly alert’ implies that in spite of all this, the dinosaur is intelligent and sharp so Ed would be unlikely to outwit it or hide.

[2 marks]

c. **Lines 17-20:** 'this beast had a broad, squat, toad-like face like that which had alarmed us in our camp. His ferocious cry and the horrible energy of his pursuit both assured me that this was surely one of the great flesh-eating dinosaurs'

- 'Beast' (noun) has connotations of ferocity and violence.
- Description of its face makes it seem ugly and vicious. 'Toad-like' is a simile and suggests slimy/lumpy/reptilian.
- 'Ferocious cry' provides aural imagery, suggesting both anger and volume.
- 'Horrible energy of his pursuit' again surprises the reader with the dinosaur's speed, in spite of its enormous size. 'Horrible' because we imagine how easily it would be able to outrun a human.
- 'Great flesh-eating dinosaurs' means carnivorous but provides a graphic depiction of what it does with its prey. Ed is possibly about to be reduced simply to 'meat'.

[2 marks]

d. **Lines 39-42:** 'he was springing in great bounds. The moonlight shone upon his huge projecting eyes, the row of enormous teeth in his open mouth, and the gleaming fringe of claws upon his short, powerful forearms.'

- Dynamic verb 'springing' tells of his lithe agility, surprising for a beast of its size. Covers huge amount of ground with each step. 'Great bounds' also emphasises the speed of this violent motion.
- 'Moonlight' - see above.
- 'Huge projecting eyes' is reptilian and ugly, implying also a sense of insanity or possibly its intelligence again.
- 'Enormous teeth' speaks of the size of these deadly weapons and 'row' implies a huge number of them. 'Open mouth', it's ready to bite and the end could come at any minute for Ed.
- Adjective 'gleaming' suggests an awful beauty in the sight, and that the weapons are primed and deadly, Visual imagery here.
- Metaphor in 'fringe' of claws also contributes to the incongruously pleasant image - suggests something sinister? A well-constructed killing machine.
- 'Short powerful forearms' once again mixes power with the blunt, compact nature of the animal.

[2 marks]

Q4. Complete the grid to show how the text is structured.

Put (1) for the first section, then (2) for the next section and so on, to show the correct sequence.

**ONE mark for each correctly-placed number**

Ed decides his only chance is to run from the beast, which he does, as fast as he can.	4
He hears the noise again and realises that a creature is hunting him.	2
The dinosaur reappears and chases Ed until he falls into a hole.	6
Ed pauses, thinking he might have shaken the dinosaur off his trail.	5
He sees the large dinosaur appear from the bushes and hopes it is harmless.	3
Walking back to camp, Ed hears a strange growling behind him.	1

[6 marks]

Q5. Look below at the short extract from the passage. Using quotations from **this section alone**, analyse how the writer makes it tense and engaging for the reader. You may wish to consider:

- exciting vocabulary choices
- sentence structure
- use of literary techniques
- anything else you notice

[6 marks]

<b>Level 3:</b> 5 or 6 marks	Clear and/or apt discussion of effect of technique, vocabulary or structural features	<ul style="list-style-type: none"> <li>• Clear and detailed discussion of effect of vocab or techniques</li> <li>• May use some subject terminology and/or relevant examples</li> <li>• Clear = bottom of the band; apt = top of the band</li> </ul>
<b>Level 2:</b> 3 or 4 marks	Some attempt to engage with vocab, technique or sentence structure; some modest success	<ul style="list-style-type: none"> <li>• Identifies feature(s). May use subject terminology with more or less accuracy</li> <li>• Makes some attempt to discuss effectiveness; top of the band for some success</li> <li>• May tend towards narrative at times lower down the band</li> </ul>

<b>Level 1:</b> <b>1 or 2 marks</b>	Simple or limited attempt to engage with vocab, technique or sentence structure	<ul style="list-style-type: none"> <li>• Some relevant discussion of the selected section but fails to engage with anything specific</li> <li>• Likely to be narrative, but top of the band if there is anything moving beyond this</li> <li>• Shows understanding of the writer making conscious choices; placement in the band depends on the depth of this understanding.</li> </ul>
--	---	---

## English: Section B - Writing

Writing will be assessed and marks allocated for:

- A wide range of vocabulary and utilising features of the form effectively
- Structure and paragraphing
- A range of sentence forms to add variety
- Spelling and punctuation

## Mathematics

### Section A

- 591
- 3240
- 456
- 277
- £18
- DBCA
- 2.8
- $\frac{2}{12}$  or  $\frac{1}{6}$
- 1h 53m
- \$28
- 39
- 26
- 31
- 1541
- 71
- 16kg
- 2, 6, 9, 18
- 7
- 11
- Seven million four hundred thousand and forty
- 70
- 2465
- 2p
- 150mins
- 1, 100, 10000
- 12
- $\frac{1}{5}$
- 1140
- £3.78
- 27930

### Section B

- TEST**
- (a) 6,5 (b) 4,1,1 (c) 9,3 (d) 7,1
- 1,1 5,0 2,1
- JBAS, JABS, JASB, JSAB, JSBA
- 21, 18
- (a) 18.3 (b) 11
- 8
- (a) £8.52 (b) 51h
- 85 cm
- (a)  $117^\circ$  (b)  $77^\circ$
- 4,3 9 2,7,6
- (a) mean 3, median 2, range 5 (b) 8, 9
- (a)  $\frac{6}{11}$  (b)  $\frac{1}{2}$  (c) 9
- (a)  $150 \text{ cm}^2$  (b)  $1530 \text{ cm}^2$
- (a) 6 (b) 9 (c) 6 (d) 4 (e) 4 or 9

## Verbal Reasoning

- careless
- smaller/house
- B
- NOT
- HOT
- TON
- eat
- G/I
- made
- colour/paint
- blue



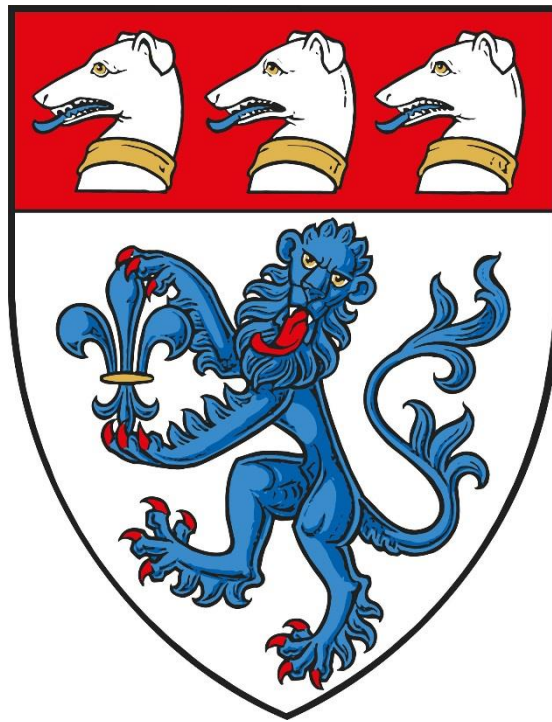

# The King's School in Macclesfield

[www.kingsmac.co.uk](http://www.kingsmac.co.uk)

01625 260000

[admissions@kingsmac.co.uk](mailto:admissions@kingsmac.co.uk)